

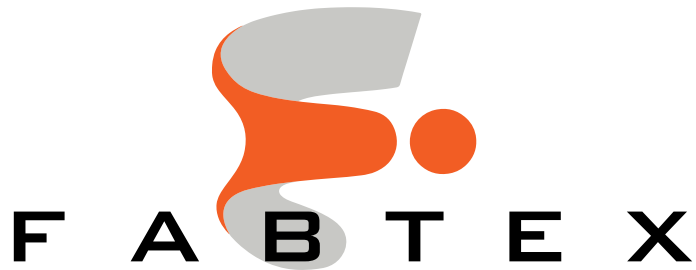

F A B T E X



ROLLER SHADE SERVICE MANUAL



ROLLER SHADE SERVICE MANUAL

VERSION 2.0 • 2023

PRODUCT DISCLAIMER

Fabtex is a manufacturer of commercial products that require installation by a licensed contractor. All information shown is for schematic purposes and to aid coordination amongst trades. All wiring, connections, means and methods are to be performed by others in strict adherence with all federal, state, and local building codes.

CONFIDENTIAL

All materials disclosed in this document are proprietary to Fabtex, Inc. The holder agrees to maintain it in confidence and must not replicate or reveal this information in any manner.

WHAT'S INSIDE

About this Guide	5
Ordering Parts	5
FT vs. ML parts	6
Parts Diagram	
Roller Shade Components	
Single Shade Non-Fascia System	7
Single Shade 4" Fascia System	8
Dual Shade 5" Fascia System	9
Motor Components	
ML-280BC Motor	10
ML-280SC Motor	11
ML-350BC Motor	12
ML-350F Motor	13
ML-350PW Motor	14
Programming	
ML Motors & Remotes	
Quick Start	15
Programming	18
Delete a Remote	19
Add Additional Remotes	19
Delete Limits	19
Correct the Upper Limit	19
Correct the Lower Limit	19
Operate Shade Manually	20
Enter User Mode	20
Mute the Motor	20
Reset to Factory Defaults	20
Turn OFF/ON Radio Frequency Receiving	20
Switch between Jog Mode and Normal Mode	20

Programming for ML-350PW	
Change Motor Rotation Direction	21
Set Motor Limits	22
FT Motors & Remotes	
Programming	24
Change Motor Direction	24
Set Limits	24
Add Additional Remotes	25
Delete a Remote	25
Reset the Limits	25
Reset to Factory Defaults	25
Alternate Programming	
Pair the Motor to the Remote	26
Set Limits	26
Switch Transmitter Frequency	26
Reset to Factory Defaults	26

Troubleshooting

ML-250B, 280BC, 280SC, 350BC, 350F Motor	27
ML-350PW Motor	28

Care & Maintenance

Care and Cleaning Methods	
Hand Dusting	29
Vacuuming with a Soft Brush Attachment	29
Damp Cloth	29
Spot Cleaning	29
Low Heat Steaming	30
Professional Cleaning	30
Product Maintenance	
Fabric-Wrapped Fascia or Cornice	30
Managing Fabric Edge Fray	
Cause of Potential Edge Fray	31
Trimming Frayed Fibers	32
Detailing the Cut Edges	33
Preventing Fabric from Rubbing on other Objects	33

ABOUT THIS GUIDE

This is a swift guide to programming your Fabtex Motors and Remotes. Kindly read this in its entirety before installing your roller shade. When in doubt or need further instruction, please don't hesitate to contact our Product Support Department:

 **800-778-2791 x 458**

All our personnel are also accessible via Microsoft Teams. Need help with Teams? Download the guide [here](#). For any feedback/suggestions to improve our process, email installs@fabtex.com.

The step-by-step installation guide of roller shades is currently *not* included in this guide. They will be available as videos at our Youtube channel by late 2023.

Fabtex Youtube Channel

ORDERING PARTS

Soon, roller shade/installation parts will be available for online ordering via the link below. For the meantime, parts may be ordered via installations@fabtex.com or 800.778.2791 x 458.

www.FabtexInstallations.com

PARTS DIAGRAM | Roller Shade Components

Single Shade Non-Fascia System

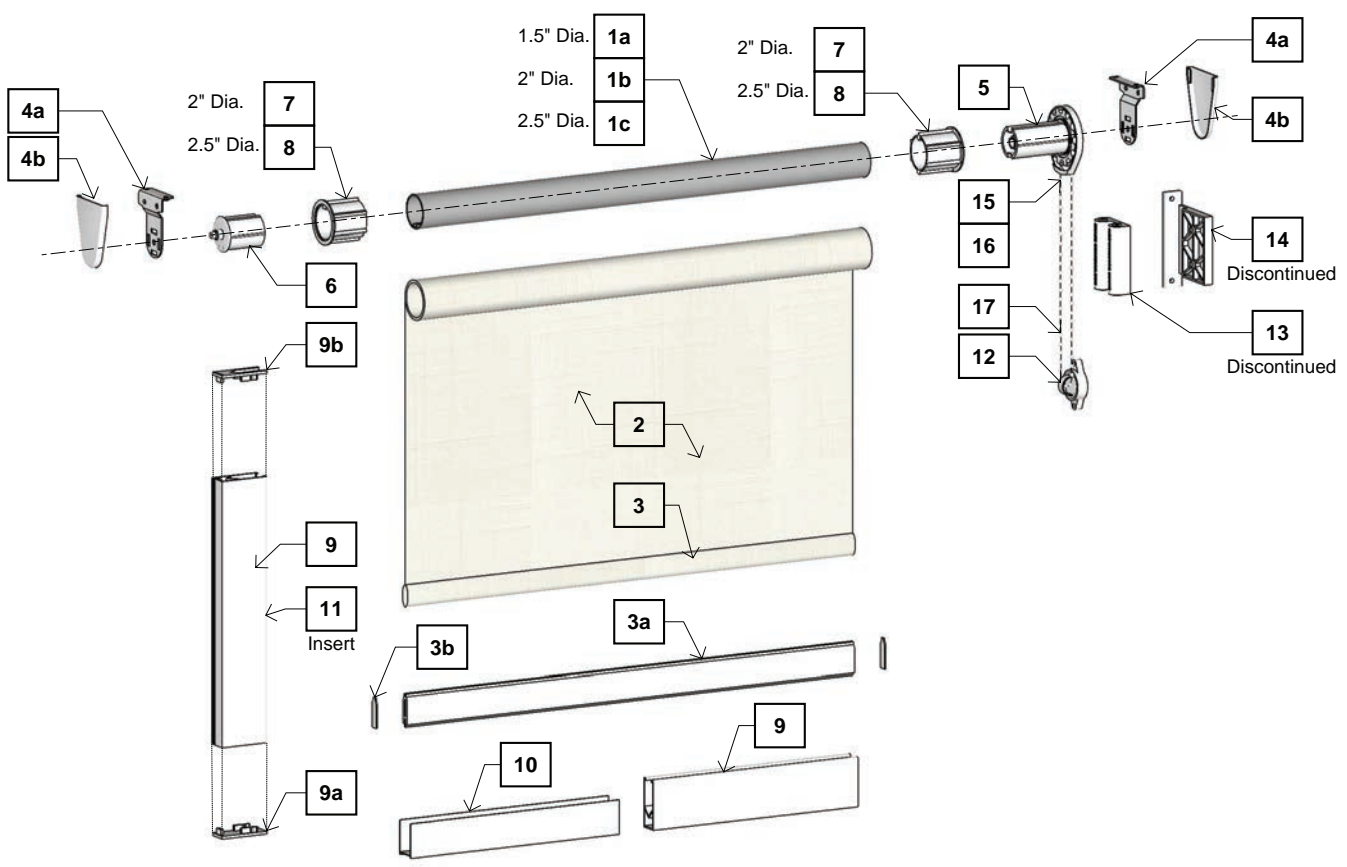

- | | | | |
|-----------|--|-----------|---------------------------------|
| 1A | 1.5" Grooved Tube | 9 | 2 Piece Side / Sill Channel |
| 1B | 2" Grooved Tube | 9A | Side Channel End Cap |
| 1C | 2.5" Structural Tube | 9B | Side Channel End Pass |
| 2 | Sheer or Blackout Fabric Band | 10 | 1 Piece Sill Channel |
| 3 | Sealed Hem Bar | 11 | Light Blocking Brush |
| 3A | External Hem Bar | 12 | Safety Hold 3 (Clear Finish) |
| 3B | External Hem Bar End Caps | 13 | Shade Guardian |
| 4A | Wall/Ceiling Single Non-Fascia Bracket | 14 | Shade Guardian Mounting Bracket |
| 4B | Bracket End Plate (Cover) | 15 | Ball Stop |
| 5 | Clutch End | 16 | Beaded Chain Connector |
| 6 | Heavy-Duty Pin End | 17 | Metal Chain Spool |
| 7 | 2" Adaptor | | |
| 8 | 2.5" Adaptor | | |

Single Shade 4" Fascia System

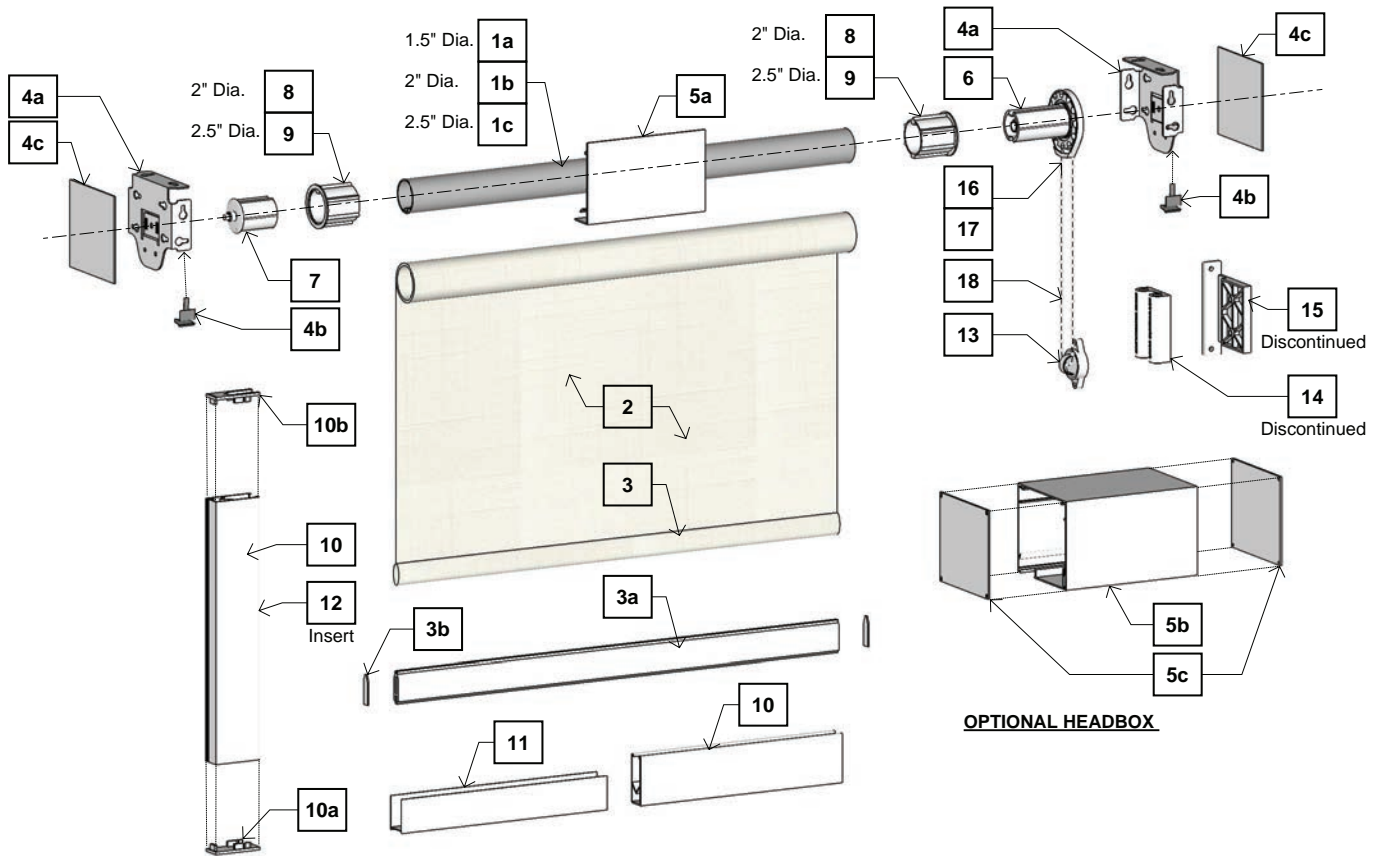

1A 1.5" Grooved Tube

1B 2" Grooved Tube

1C 2.5" Structural Tube

2 Sheer or Blackout Fabric Band

3 Sealed Hem Bar

3A External Hem Bar

3B External Hem Bar End Caps

4A Fascia Bracket 4"

4B Fascia Bracket Clip

4C 4" Bracket Cover

5A 4" Square Fascia

5B 4" Headbox

5C 4"x4" Headbox End Plate

6 Clutch End

7 Heavy-Duty Pin End

8 2" Adaptor

9 2.5" Adaptor

10 2 Piece Side / Sill Channel

10A Side Channel End Cap

10B Side Channel End Pass

11 1 Piece Sill Channel

12 Light Blocking Brush

13 Safety Hold 3 (Clear Finish)

14 Shade Guardian

15 Shade Guardian Mounting Bracket

16 Ball Stop

17 Beaded Chain Connector

18 Metal Chain Spool

Dual Shade 5" Fascia System

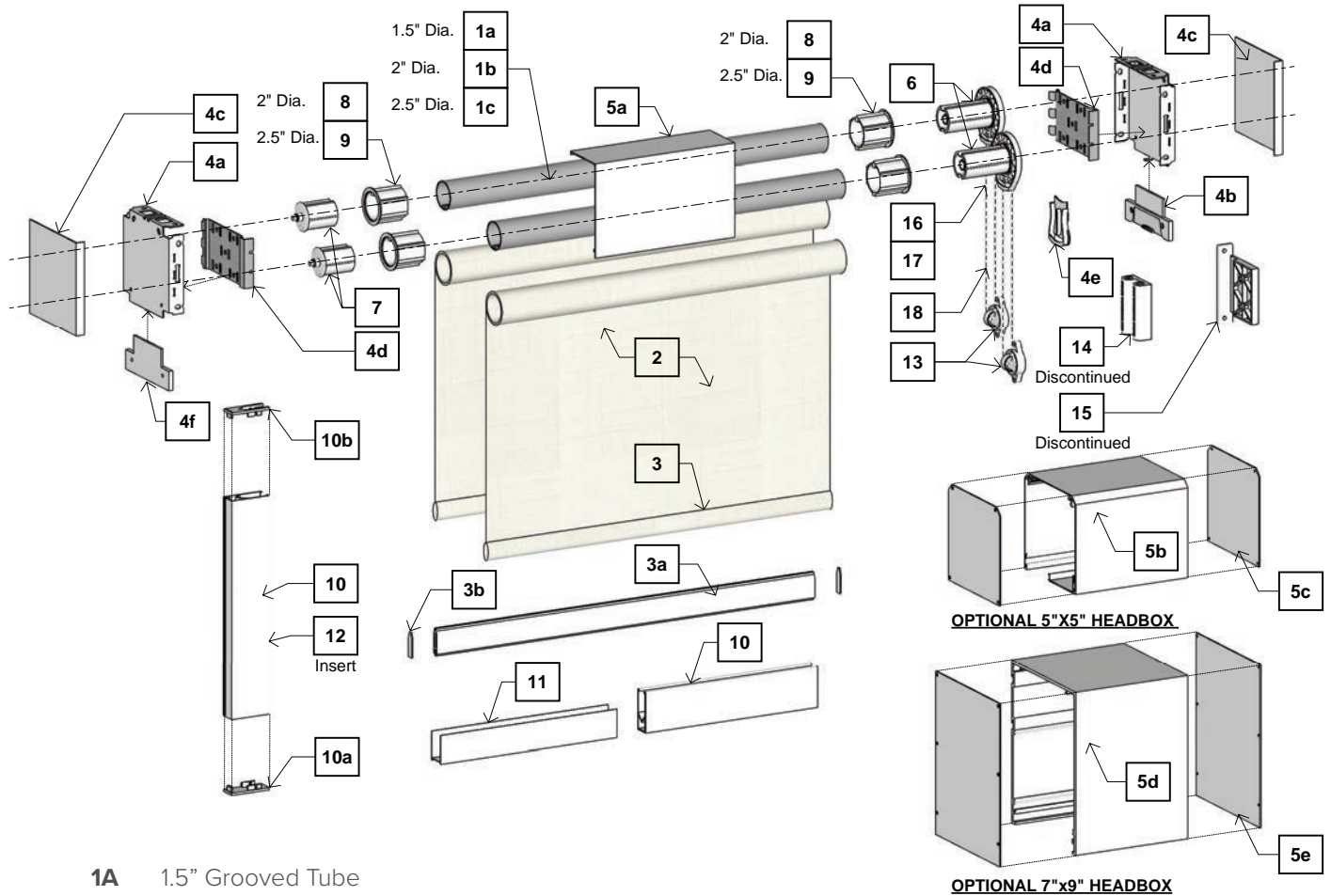

- 1A** 1.5" Grooved Tube
- 1B** 2" Grooved Tube
- 1C** 2.5" Structural Tube
- 2** Sheer or Blackout Fabric Band
- 3** Sealed Hem Bar
- 3A** External Hem Bar
- 3B** External Hem Bar End Caps
- 4A** Fascia Bracket 5"
- 4B** Dual Diverter
- 4C** 5" Bracket Cover
- 4D** Galvanized Insert
- 4E** Dual Chain Guide
- 4F** Pin End Guide
- 5A** 5" Square Fascia
- 5B** 5" Headbox
- 5C** 5"x5" Headbox End Plate
- 5D** 7"x9" Headbox
- 5E** 7"x9" Headbox End Plate

- 6** Clutch End
- 7** Heavy-Duty Pin End
- 8** 2" Adaptor
- 9** 2.5" Adaptor
- 10** 2 Piece Side / Sill Channel
- 10A** Side Channel End Cap
- 10B** Side Channel End Pass
- 11** 1 Piece Sill Channel
- 12** Light Blocking Brush
- 13** Safety Hold 3 (Clear Finish)
- 14** Shade Guardian
- 15** Shade Guardian Mounting Bracket
- 16** Ball Stop
- 17** Beaded Chain Connector
- 18** Metal Chain Spool

PARTS DIAGRAM | Motor Components

ML-280BC Motor

(Internal Battery Operated Motor with RF Controls)

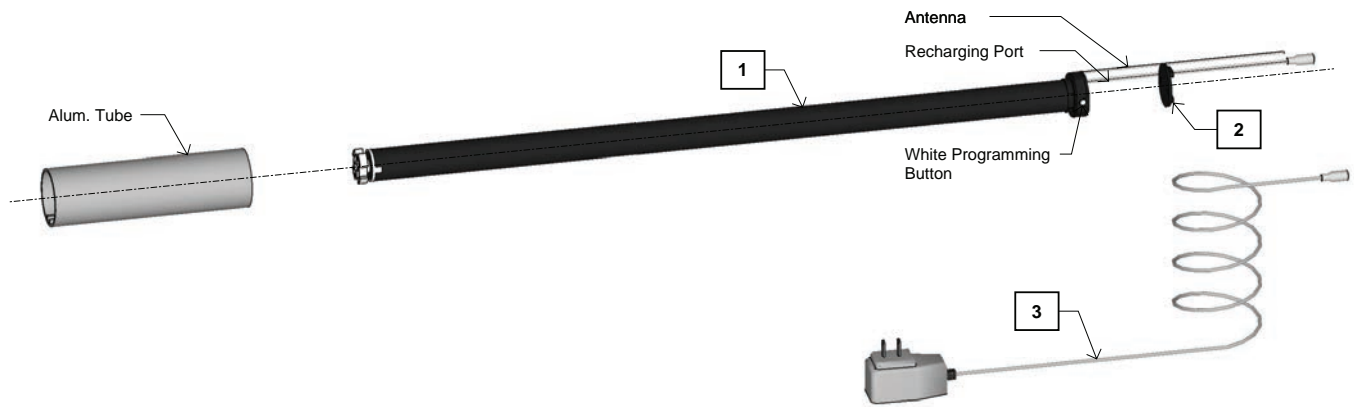

4a

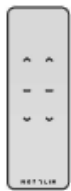

4b



4c

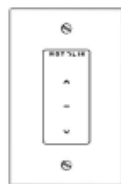

5a

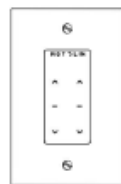

5b

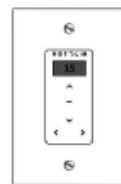

5c



6a



6b

Handheld Remote Controls

Recessed (In-wall Switch)

Surface Mount

- 1** 2" Tubular Motor
- 2** Skyline Adapter
- 3** Wall Charger
- 4A** Hand Held 1 Channel Shade RF Control
- 4B** Hand Held 2 Channel Shade RF Control
- 4C** Hand Held 15 Channel Shade RF Control

- 5A** In-Wall 1 Channel Shade RF Control
- 5B** In-Wall 2 Channel Shade RF Control
- 5C** In-Wall 15 Channel Shade RF Control
- 6A** Surface Mount 1 Channel Shade RF Control
- 6B** Surface Mount 2 Channel Shade RF Control

ML-280SC Motor

(External Battery Operated Motor with RF Controls)

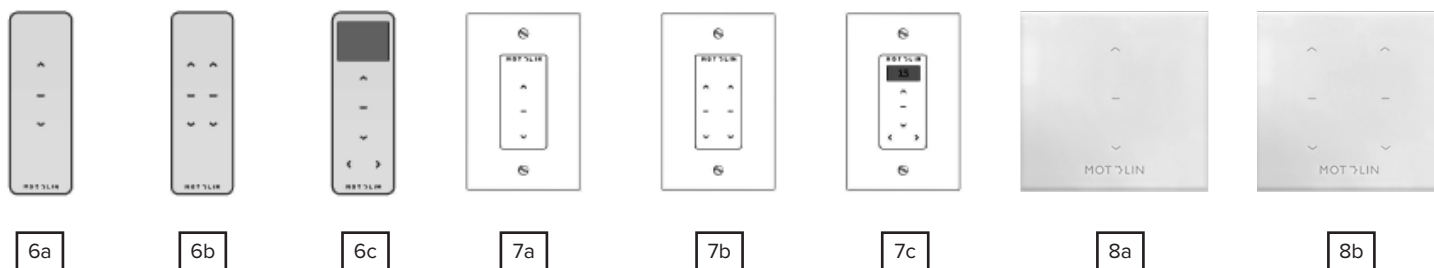
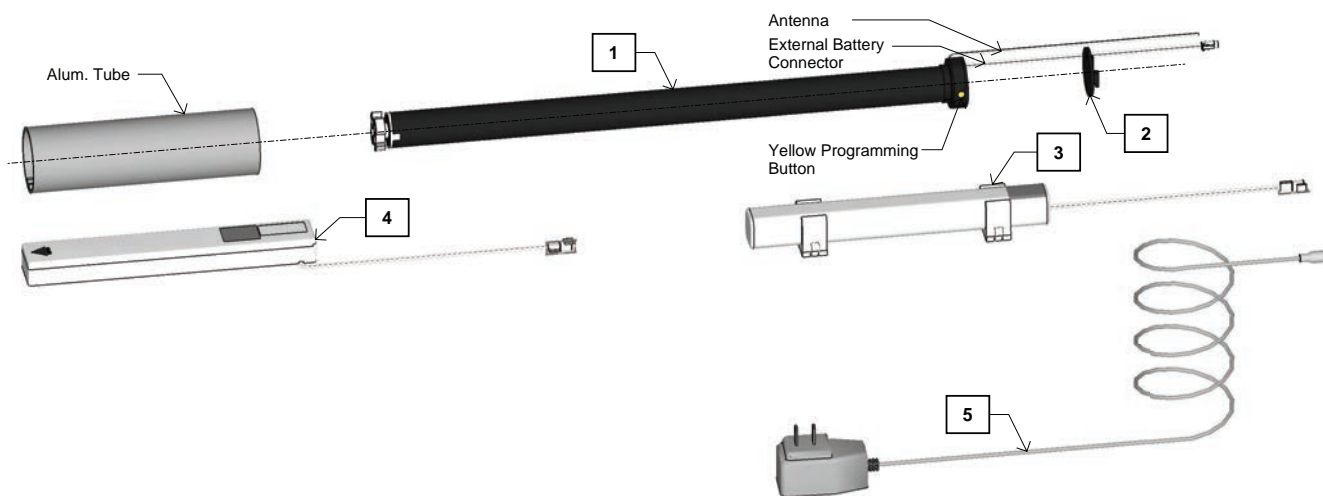

Handheld Remote Controls

Recessed (In-wall Switch)

Surface Mount

- 1** 1.5" Tubular Motor
- 2** Skyline Adapter
- 3** Lithium-ion Rechargeable Battery Pack
- 4** AA Battery Pack
- 5** Wall Charger
- 6A** Hand Held 1 Channel Shade RF Control
- 6B** Hand Held 2 Channel Shade RF Control
- 6C** Hand Held 15 Channel Shade RF Control
- 7A** In-Wall 1 Channel Shade RF Control
- 7B** In-Wall 2 Channel Shade RF Control
- 7C** In-Wall 15 Channel Shade RF Control
- 8A** Surface Mount 1 Channel Shade RF Control
- 8B** Surface Mount 2 Channel Shade RF Control

ML-350BC Motor

(Internal Battery Operated Motor with RF Controls)

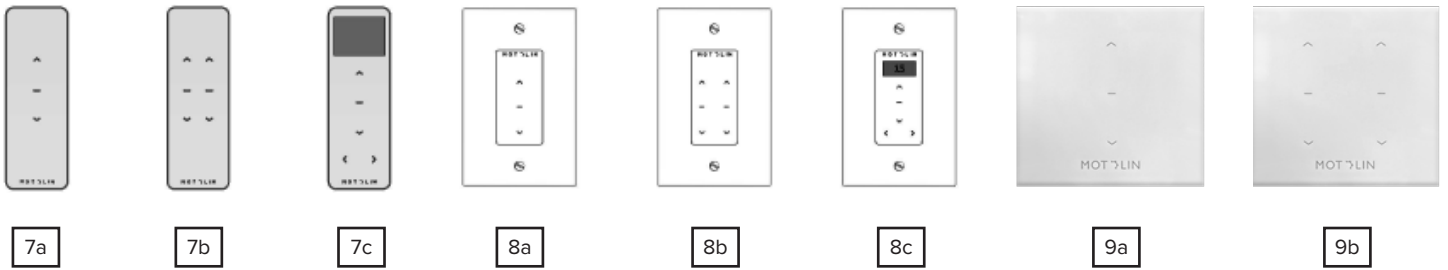
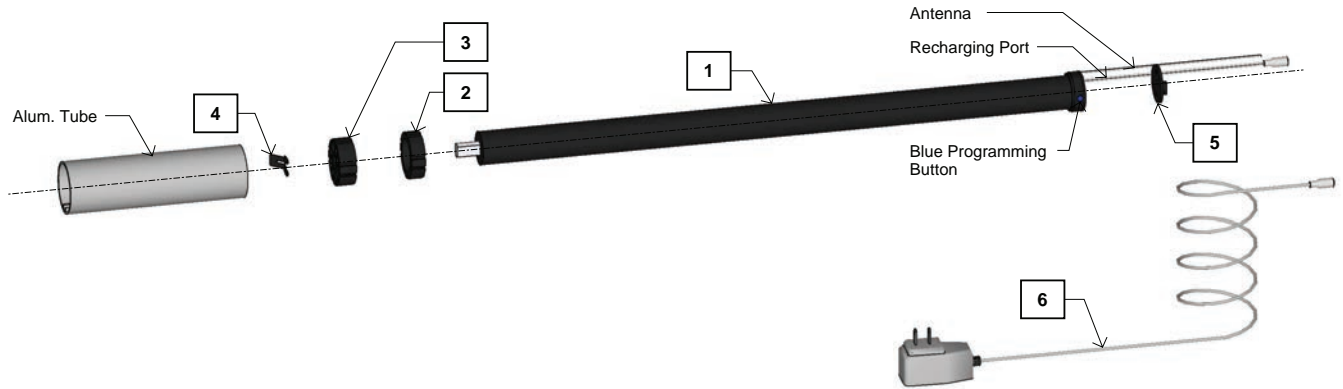

Handheld Remote Controls

Recessed (In-wall Switch)

Surface Mount

- 1** 2" Tubular Motor
- 2** 2" Crown
- 3** 2" Drive
- 4** Drive Clip
- 5** Skyline Adapter
- 6** Wall Charger
- 7A** Hand Held 1 Channel Shade RF Control
- 7B** Hand Held 2 Channel Shade RF Control
- 7C** Hand Held 15 Channel Shade RF Control

- 8A** In-Wall 1 Channel Shade RF Control
- 8B** In-Wall 2 Channel Shade RF Control
- 8C** In-Wall 15 Channel Shade RF Control
- 9A** Surface Mount 1 Channel Shade RF Control
- 9B** Surface Mount 2 Channel Shade RF Control

ML-350F Motor

(Plug In/Hardwired Application with RF Controls)

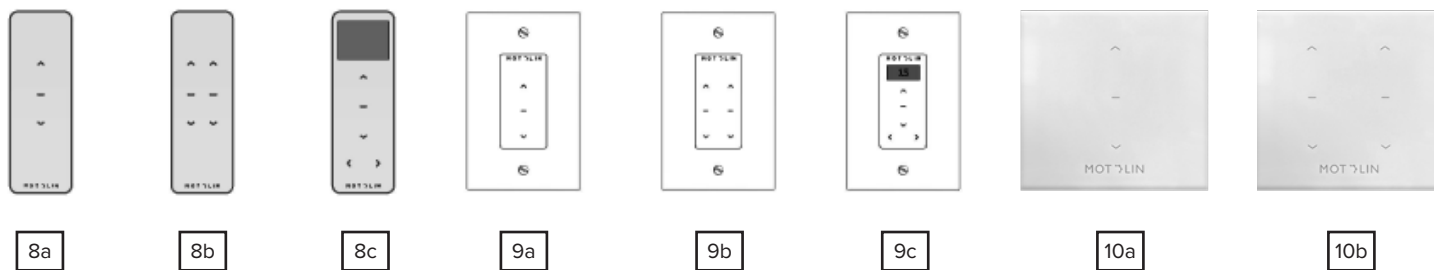
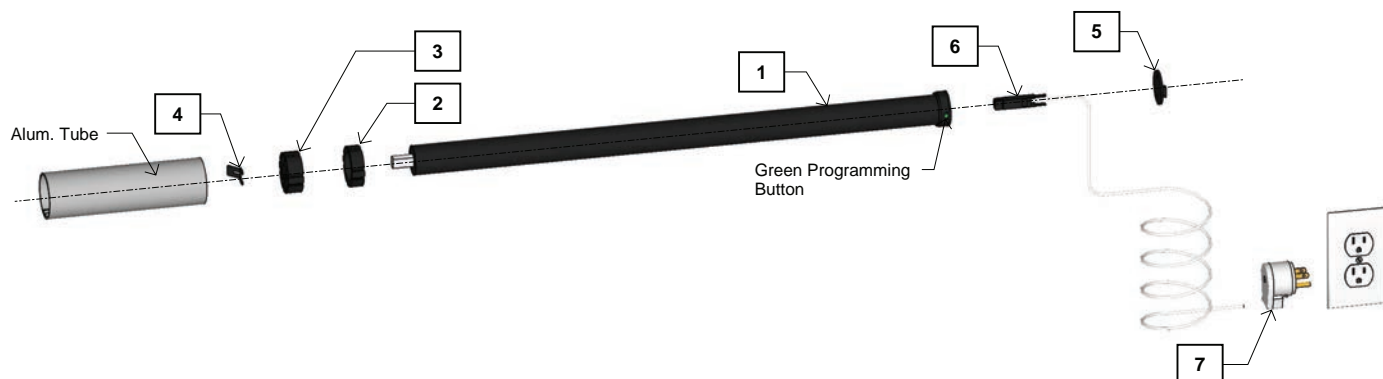

Handheld Remote Controls

Recessed (In-wall Switch)

Surface Mount

- | | | | |
|-----------|---|------------|--|
| 1 | 2" Tubular Motor | 8A | Hand Held 1 Channel Shade RF Control |
| 2 | 2" Crown | 8B | Hand Held 2 Channel Shade RF Control |
| 3 | 2" Drive | 8C | Hand Held 15 Channel Shade RF Control |
| 4 | Drive Clip | 9A | In-Wall 1 Channel Shade RF Control |
| 5 | Skyline Adapter | 9B | In-Wall 2 Channel Shade RF Control |
| 6A | Tubular Motor Cord, 4 wire, 2 meters (78") | 9C | In-Wall 15 Channel Shade RF Control |
| 6B | Tubular Motor Cord, 4 wire, 4 meters (156") | 10A | Surface Mount 1 Channel Shade RF Control |
| 6C | Tubular Motor Cord, 4 wire, 8 meters (312") | 10B | Surface Mount 2 Channel Shade RF Control |
| 7 | Right Angle Plug (White) | | |

ML-350PW Motor

(Hardwired Application with Hardwired Controls)

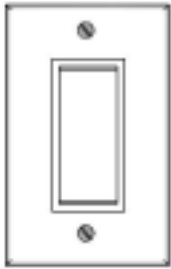
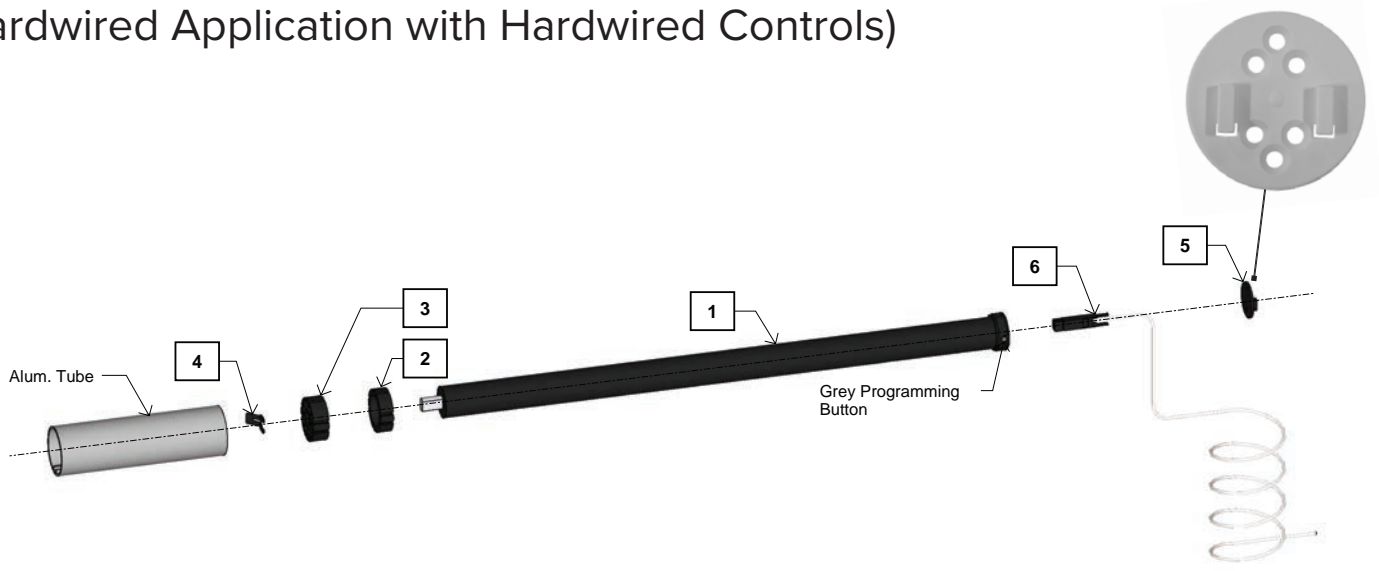

Single Roller Shade

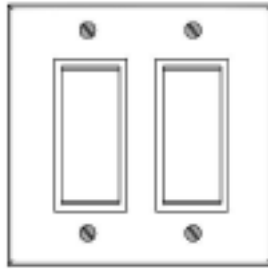

Dual Roller Shade

Leviton #5657-2 Momentary Contact, SPDT Center Off Switch & face plate to be provided by EC/GC (or equal).

- 1** 2" Tubular Motor
- 2** 2" Crown
- 3** 2" Drive
- 4** Drive Clip
- 5** Skyline Adapter

- 6A** Tubular Motor Cord, 4 wire, 2 meters (78") Tubular
- 6B** Motor Cord, 4 wire, 4 meters (156")
- 6C** Tubular Motor Cord, 4 wire, 8 meters (312")
- 7** Hardwired Single Rocker Switch
- Hardwired Double Rocker Switch

PROGRAMMING | ML Motors & Remotes

Quick Start

For models ML-250B | ML-280BC | ML-280SC | ML-350BC | ML-350F

Follow steps 1 - 5 to program the motor and the remote. Once completed, the motor will automatically revert to User Mode. Motors must be programmed individually; this can be done by disconnecting power or utilizing the RF on/off function for motors within “hearing” distance.

Definitions

- Beep** : short high-pitched sound emitted by the motor.
- Jog** : motor movement where it runs up/down in a single short cycle.
- Motor** : device that converts electric energy into mechanical energy and the driving mechanism of our roller shades.
- Remote:** device used for wireless control of the motor; communicates with the motor via RF (Radio Frequency); also called a Transmitter or Control/Controller.

ROLLER SHADE MOTOR

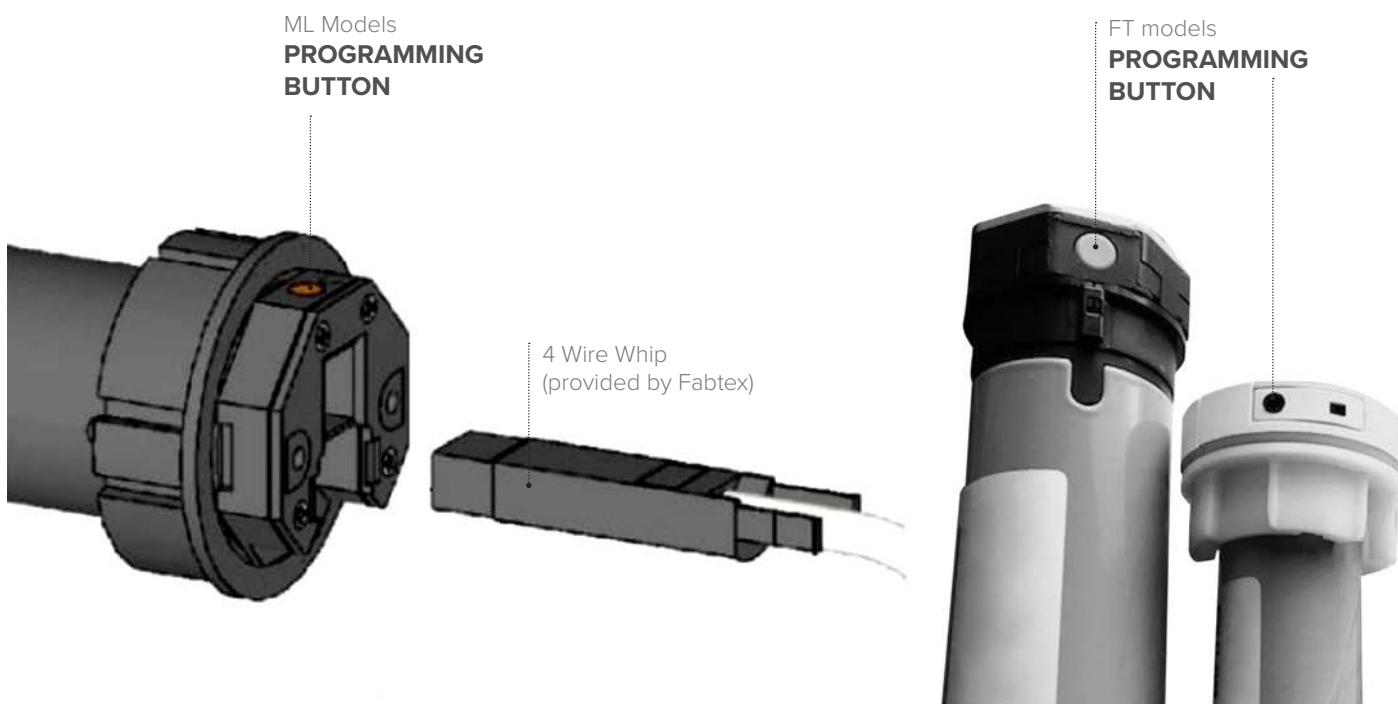

The color of programming buttons vary depending on the motor type:

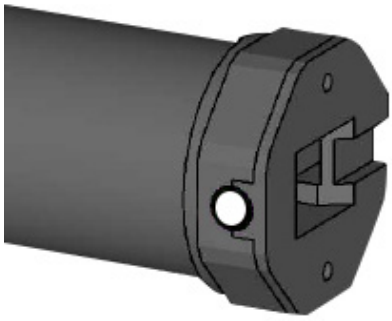

 **ML-280BC Motor**
Internal Battery Operated Motor
with RF Controls

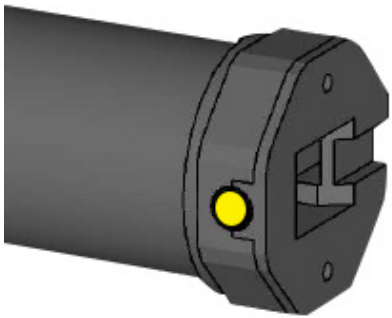

 **ML-280SC Motor**
External Battery Operated Motor
with RF Controls

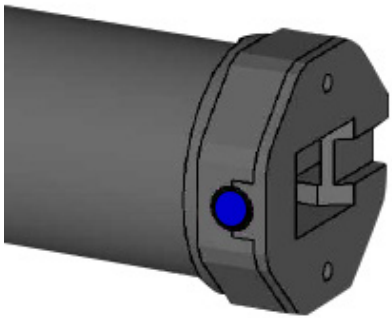

 **ML-350BC Motor**
Internal Battery Operated Motor
with RF Controls

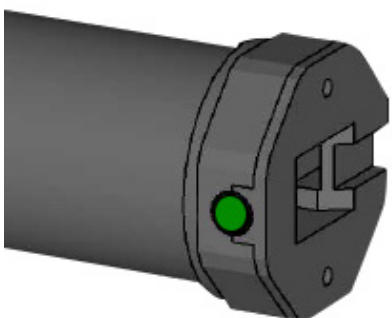

 **ML-350F Motor**
Plug In/Hardwired Application
with RF Controls

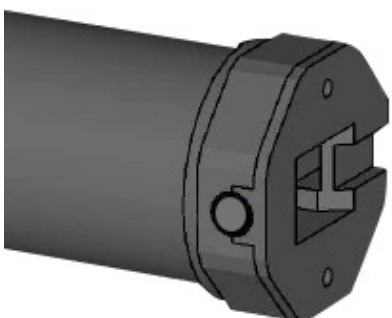

 **ML-350PW Motor**
Hardwired Application
with Hardwired Controls

REMOTE FRONT

REMOTE BACK

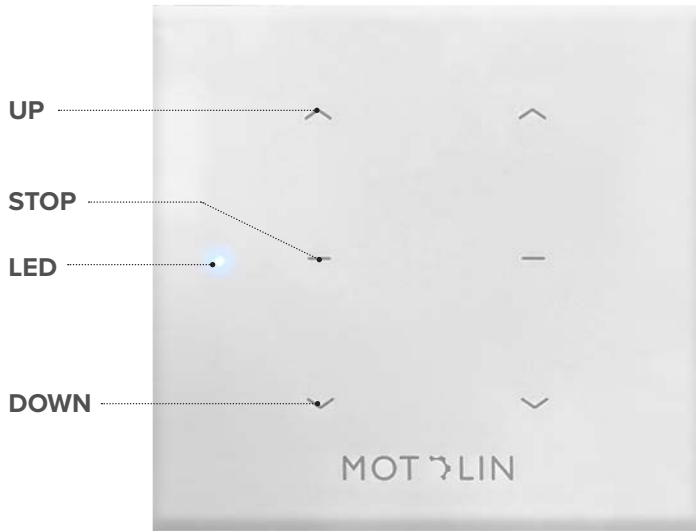

PROGRAM or P2
Works with right controls

BATTERY SLOT
Battery: CR2430 3V

PROGRAM or P2
Works with left controls

The UP, STOP, DOWN & P2 buttons are used for programming. During programming, the time between commands must be less than 4 seconds or the motor will exit Program Mode.

Just as physical obstacles can prevent you from passing from one room to another (walls, for example), obstacles can block, reduce, or reflect signals, too. The frequency of the remote's signal, 433MHz, comes into play, as does the composition of the walls— brick, drywall, glass, and steel all have different properties. Ultimately, the range of the remote depends on the environment in which the shading system is deployed.

Programming

Step 1: Power Up

With the roller shade installed, connect power. The motor will confirm power with a beep and jog. At this point the motor will be in program mode for 10 seconds.

Step 2: Pair Motor to Remote

1. If it has been more than 10 seconds since powering up, the motor will need to be put back into Programming Mode. To do this, Press the PROGRAM button on the MOTOR for 2 seconds, the motor will Beep and Jog, entering into pairing mode for 10 seconds.
2. Press and hold STOP for 3 seconds. The motor will jog twice and beep three times, signaling the remote is paired to the motor.

Note: In programming mode, the motor will move in ½” increments. Press and Hold UP or DOWN direction for faster travel.

Step 3: Reverse Remote Direction

Check if the remote’s arrow directions operate as intended. To reverse directions:

Via REMOTE: press & hold up/down simultaneously until it jogs (2-3 seconds), signaling the control direction has changed.

Via MOTOR: Press & hold Program button, releasing after the 3rd jog (8-10 seconds). The motor will beep/jog confirming the direction has changed.

Step 4: Set Limits

Adjust to the desired upper limit set point— The motor will be in jog mode. Press & hold (UP+STOP) simultaneously until motor jogs (2-3 seconds).

Adjust to desired lower limit set point. Press & hold (DOWN+STOP) simultaneously until motor jogs (2-3 seconds).

Step 5: Enter User Mode

Motor automatically enters User Mode upon setting the top & bottom limits. Confirm programming is complete by testing the upper and lower limits via the remote. At this point, your programming is complete.

Delete a Remote < P2, Stop, P2 >

1. Press the PROGRAM button on the REMOTE once, the motor will jog once and beep once.
2. Press the STOP button once, the motor will jog once and beep once.
3. Press the PROGRAM button on the REMOTE once, the motor will jog twice and beep three times to signal that the remote has been deleted.

Add Additional Remotes

1. Press the PROGRAM button on the already paired REMOTE twice.
2. Press the PROGRAM button once on the new REMOTE. The MOTOR will beep 3 times and jog to confirm addition of the remote.

Delete Limits <P2, Down, P2 >

1. Press the PROGRAM button on the REMOTE once, the motor will jog once and beep once.
2. Press the DOWN button once, the motor will jog once and beep once.
3. Press PROGRAM button on the REMOTE once, the motor will jog twice and beep three times to signal that all limits have been deleted.

Correct the Upper Limit

1. Press & hold (UP+STOP) for five seconds, the motor will jog once and beep once.
2. Go to new desired stop position. Motor will be in Jog Mode.
3. Press & hold (UP+STOP) for two seconds, the motor will jog twice and beep three times to signal that the new upper limit is set.

Correct the Lower Limit

1. Press & hold (DOWN+STOP) for five seconds, the motor will jog once and beep once.
2. Go to new desired stop position. Motor will be in Jog Mode.
3. Press & hold (DOWN+STOP) for two seconds, the motor will jog twice and beep three times to signal that the new lower limit is set.

Operate Shade Manually

1. Short press the PROGRAM button on the MOTOR. Motor will go up, stop, or go down. Top & bottom limits must be set for this function.

Enter User Mode

ML motors have an advanced feature that allows dual button presses to work. To prevent accidental programming when users press and hold 2 buttons at once, it is recommended to put the remote into User Mode after programming is complete.

Press & hold STOP until the blue indicator light on the remote stops flashing and turns solid blue (approximately 15 seconds) to enter User Mode. This will prevent the user from using button combinations and accidentally making programming changes.

Repeat the process to switch back to Programming Mode.

Mute the Motor

This will “mute” the motor when you do not want it to respond to commands from the remote to which it is paired. This is used most often when programming multiple motors to the same remote.

Press & hold the PROGRAM button on the MOTOR for 2 jogs (approximately 6 seconds). Release immediately after the 2nd jog. The motor will beep 2 times to confirm.

Pressing the PROGRAM button on the MOTOR once will restore it to normal operation.

Reset to Factory Defaults

Press & hold the PROGRAM button on the MOTOR, releasing after the 4th jog (12-14 seconds). The motor will beep/jog 4 times confirming the factory reset.

Switch between Jog Mode and Normal Mode

1. Press & hold (UP+DOWN) for five seconds, the motor will jog once.
2. Press STOP once, the motor will jog twice and beep three times to signal the mode has changed.

Programming for ML-350PW

Or SMA FT-350PW 4 – wire motors: Leviton 5657-2W

Note! Motor must be correctly wired to switch to program. Refer to next pages for diagrams.

4 – Wires from motor side

- Red = Direction 1
- Black = Direction 2
- White = Neutral
- Green = Ground

3 – Wires from house side [Wire color may differ]

- Green = Ground
- White = Neutral
- Black = 120VAC

SPDT center neutral [Leviton 5657-2W]– rocker switch

[A licensed electrician required to complete wiring connections]

- Red (Direction 1) motor wire to “UP” activated position on control switch
- Black (Direction 2) motor wire to “Down” activated position on control switch
- White (Neutral) motor wire combined with neutral house wire
- Green (Ground) Motor wire combined with house ground wire

Change Motor Rotation Direction

1. Confirm travel direction of shade: Press “Down” on switch and confirm direction of shade moves down.
 - a. Motor on right side of window: Red (Direction 1) is “Up” & Black (Direction 2) is “Down”
 - b. Motor on left side of window: Red (Direction 1) is “Down” & Black (Direction 2) is “Up”
2. If travel direction is reversed swap Direction 1 & 2 wires on rocker switch.
 - a. Confirm travel direction of shade matches switch.

Set Motor Limits

1. Identify the “Orange” program button on the head of the motor at end of shade.
2. Set bottom limit: Press “Down” on switch, once shade reaches desired bottom limit; simultaneously press the “Orange” program button on motor.
 - a. If shade stops prior to desired bottom limit: simultaneously press “Down” on switch and tap or hold “Orange” program button on motor until desired bottom limit is met.
 - b. If shade exceeds bottom limit: Press “Up” on switch passing desired bottom limit and repeat instructions 2a.
3. Set upper limit: Press “Up” on switch, once shade reaches desired upper limit; simultaneously press the “Orange” program button on motor.
 - a. If shade stops prior to desired upper limit: simultaneously press “Up” on switch and tap or hold “Orange” program button on motor until desired upper limit is met.
 - b. If shade exceeds upper limit: Press “Down” on switch passing desired upper limit and repeat instructions 3a.
4. Test top and bottom limits are set.

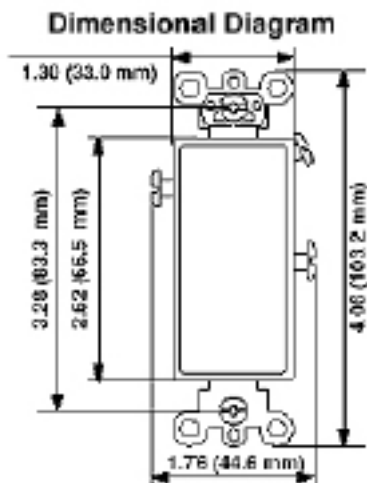

DIMENSIONAL DIAGRAM: LEVITON 5657-2W

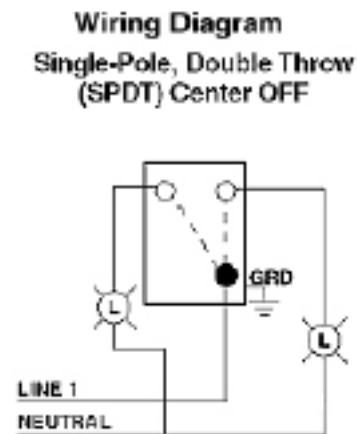

WIRING DIAGRAM: SPDT LEVITON 5657-2W

Fabtex Standard 4-Wire Motor

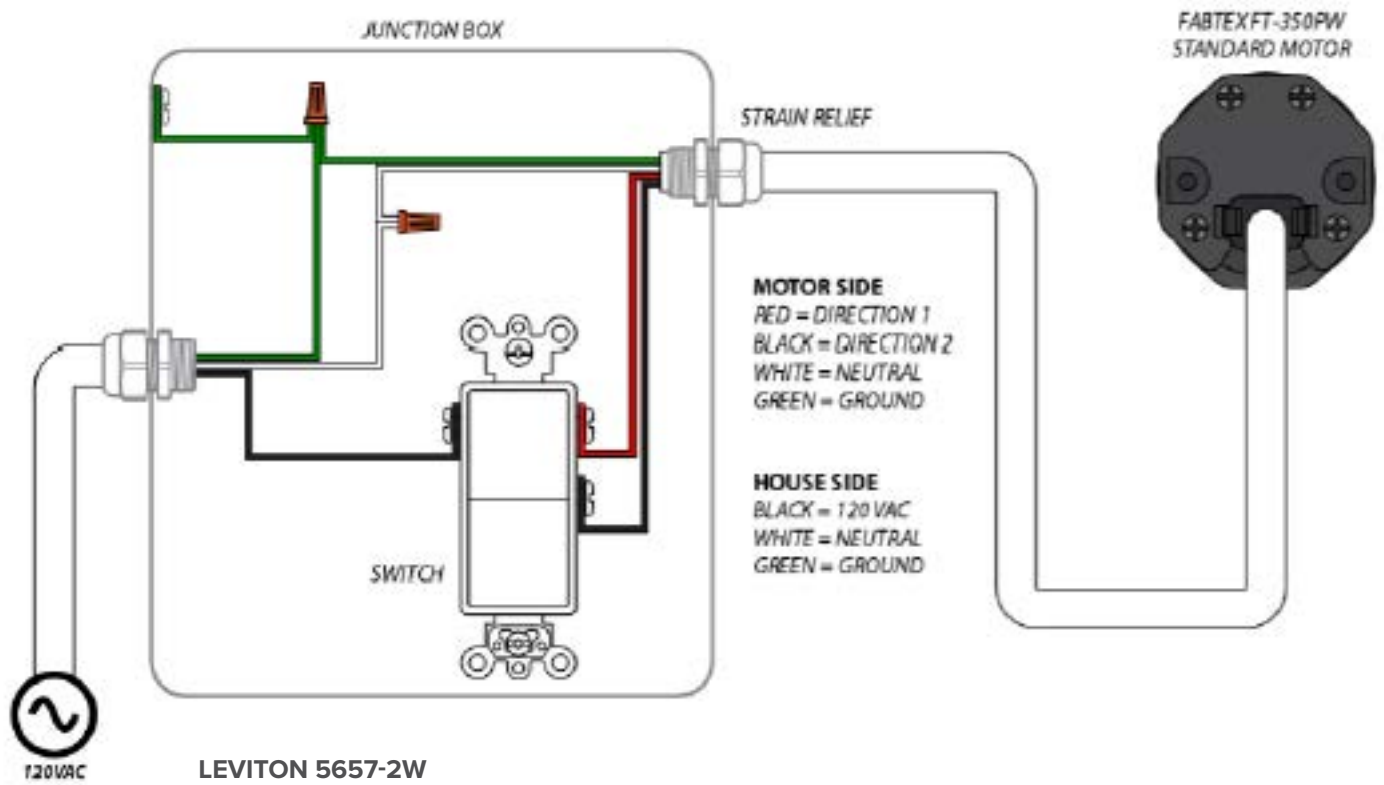

As a single channel switch, the FT-551RS requires the use of only 1 of the program buttons located on its back. See diagram on cover page. During programming, the time between the commands detailed below must be less than 4 seconds or the motor will exit program mode.

Programming

1. Press PROGRAM button on the MOTOR for 2 seconds. The motor will beep and jog confirming entry into programming mode.
2. Press P2 button on the REMOTE once, motor will beep and jog.
3. Press P2 button on the REMOTE once again, motor will beep.
4. Press the UP button on the REMOTE once, the motor will jog and beep 6 times to confirm.
5. Verify control of the shade in both directions and binding is complete. If shade runs in reverse, see Change Motor Direction.

Change Motor Direction

Used to change the motor rotation and allow the shade direction of operation to match the marking on the controls.

1. Press and hold the PROGRAM button on the MOTOR for 2 jogs, or approximately 6 seconds. Immediately upon the 2nd motor jog, release the PROGRAM button.
2. The motor will beep twice to confirm the change.

Set Limits

1. Press PROGRAM button on REMOTE once; motor will beep and jog.
2. Press the UP button once, motor will beep and jog.
3. Press PROGRAM button on REMOTE once again, motor will beep 4 times and jog.
4. Adjust to the desired upper limit set point.
5. Press and hold STOP until the motor responds with a small jog, approximately 5 seconds.
6. Adjust to desired lower limit set point.
7. Press and hold STOP until the motor responds with a small jog, approximately 5 seconds.

Add Additional Remotes

1. Press the PROGRAM button on the EXISTING REMOTE once, the motor will beep and jog.
2. Press the PROGRAM button on the EXISTING REMOTE once again, the motor will beep and jog.
3. Press the PROGRAM button on the NEW REMOTE once, the motor will beep 7 times and jog.

Delete a Remote < P2, Stop, P2 >

When multiple transmitters have been added to a single motor, this method allows removal of a single transmitter on which this operation is performed. Motor limits and all other transmitters that have been programmed the motor will stay in memory. To remove all transmitters, perform a motor reset.

1. Press the PROGRAM button once on the REMOTE you want to KEEP, the motor will beep and jog.
2. Press the PROGRAM button once on the REMOTE you want to KEEP again, the motor will beep and jog.
3. Press the PROGRAM button once on the REMOTE you want to REMOVE, the motor will beep 5 times and jog.

Reset the Limits

1. Press PROGRAM on the REMOTE once; motor will beep and jog.
2. Press STOP button on the REMOTE once; motor will beep and jog.
3. Press PROGRAM on the REMOTE once again; motor will beep 4 times and jog.
4. Limits have been deleted. Proceed to the limit setting procedure.

Reset to Factory Defaults

1. Press and hold the PROGRAM button on the MOTOR for 3 jogs, approximately 10 seconds. Immediately upon the 3rd motor jog, release the PROGRAM button.
2. The motor will beep three times to confirm. Factory reset is complete.

Alternate Programming for FT motors & remotes

If you encounter difficulties with the previous steps, try these alternate methods:

Pair the Motor to the Remote

1. Press the PROGRAM button on the MOTOR for 2 seconds, the motor will beep and jog, entering into pairing mode for 10 seconds.
2. Press the PROGRAM button on the REMOTE once, the MOTOR will beep.
3. Press the PROGRAM button on the REMOTE once again, the MOTOR will beep again.
4. Press the UP button on the REMOTE once, the MOTOR will beep 4 times and jog.

Set Limits

1. Press the PROGRAM button on the REMOTE once, motor will beep.
2. Press the UP button once, the motor will beep.
3. Press the PROGRAM button on the REMOTE once again, the motor will beep 3 times and jog.
4. Go to the upper limit point and set it by pressing & holding STOP for 5 seconds until the motor responds with a jog.
5. Go to the lower limit point and set it by pressing & holding STOP for 5 seconds until the motor responds with a jog.

Switch Transmitter Frequency — AM/FM (or Switch between FT & ML Modes)

New, unprogrammed wireless wall switches come from the factory in ML (FM) mode. To make it operate in FT (AM) mode:

1. Determine the frequency. Press P2 once. The REMOTE will respond by emitting a blue light at the front:
 - 3 quick blue flashes = ML Motor (FM)
 - 1 solid blue flash = FT Motor (AM)
2. Remove the battery in the REMOTE.
3. Press and hold the P2 button with the battery out.
4. Replace/insert the battery and release the P2 button.

Reset to Factory Defaults

Press & hold the PROGRAM button on the MOTOR, releasing after 3 jogs (6-8 seconds).
1st motor jog at the 2-4 second mark— keep holding;
2nd motor jog at the 4-6 second mark— keep holding;
3rd motor jog at the 6-8 second mark— release the PROGRAM button.
The MOTOR will beep 3 times to confirm the change.

TROUBLESHOOTING

ML-250B, 280BC, 280SC, 350BC, 350F Motors

SYMPTOM	POSSIBLE CAUSE	SOLUTION
Motor not responding	<ol style="list-style-type: none"> 1. Low/No Charge 2. Radio frequency disabled 	<ol style="list-style-type: none"> 1. Charge Motor or check power source 2. Enable Radio Frequency 3. Factory Reset Motor
Motor operating backwards	Motor is reversed	Switch Control Direction using programming instructions
Motor does not stop at top and/or bottom	Motor limits are not set or are incorrect	Correct Upper/Lower limits on programming instructions
Remote does not communicate with motor	<ol style="list-style-type: none"> 1. Remote battery low 2. Radio Frequency Disabled 3. Remote not paired to motor 4. Motor Low/ No Charge 5. Remote on wrong frequency 	<ol style="list-style-type: none"> 1. Replace Remote battery 2. Enable Radio Frequency 3. Bind motor to Remote on programming instructions 4. Charge Motor 5. Swap Remote frequency

ML-350PW Motor

SYMPTOM	POSSIBLE CAUSE	SOLUTION
Motor not responding	<ol style="list-style-type: none">1. No Power2. Wiring Error	<ol style="list-style-type: none">1. Check power source and confirm2. Verify rocker switch wiring with electrician
Motor operating backwards	Motor is reversed	Switch Control Direction by swapping throw direction wires
Motor does not stop at top and/or bottom	Motor limits are not set or are incorrect	Correct Upper/Lower limits on programming instructions

CARE & MAINTENANCE

Care and Cleaning Methods



Hand Dusting

Most routine care of Fabtex window treatments will consist of dust removal. Hand dusting is best done using gentle methods which minimize the possibility of damaging or disturbing woven fabrics, lift cords, venetian slats, etc. Soft filament and feather dusters are recommended. Careful wiping with a soft, lint-free cloth may also be effective.



Vacuuming with a Soft Brush Attachment

When hand dusting isn't practical due to the height of a window or other factors, vacuuming is an effective method. Use a soft brush attachment to temper the strength of suction and help lift unwanted dust and fibers from the surface of fabrics, cornices, and lineals. Rigorous vacuuming can distort the fabric and is not recommended.



Damp Cloth

If unresolved soiled areas remain after dusting and vacuuming, they may be cleaned with a damp cloth. Use a clean, white, lint-free cloth, lightly dampened with clean water only. Wring the cloth thoroughly to prevent excess water. Wipe gently with light pressure only. Hard, fast, or excessive rubbing can distort the fabric and is not recommended.



Spot Cleaning

If your roller shade becomes soiled or stained, spot cleaning with a mild soap and water solution may be appropriate. Use detergent that is intended for fabrics and does NOT contain fabric softener additives or harsh chemicals such as bleach, ammonia, abrasives, solvent-based cleaners, etc. Apply diluted detergent by blotting with a clean cloth. Do not rub. Then, use a second clean cloth to apply a clear-water rinse. Air dry, ensuring adequate ventilation for roller shade.

Any cleaning product should be tested on a small, inconspicuous area prior to broad application on the shade panel.



Low Heat Steaming

Steam cleaning is **NOT** recommended. Also avoid hot water when cleaning fabrics.



Professional Cleaning

Reputable drapery and upholstery cleaning services are experts in fabric care and the cleaning methods that work best for specific materials. The methods referenced in this guide are:

Ultrasonic: Usually involves taking down the window treatment and dipping in an ultrasonic bath. This is a very effective cleaning method, and may even include anti-static treatment to help repel dust.

Injection/Extraction: Similar to the popular carpet cleaning method, loose dust and dirt are removed with a vacuum, then, a cleaning solvent is applied, (injection), and immediately suctioned out, (extraction). This heat and agitation-free method can often be performed with shades and drapes left in place.

Dry Cleaning: Typically appropriate for drapery fabrics, this method is actually similar to injection/extraction, but is usually done off-site, although service providers who offer on-site dry cleaning do exist.

Product Maintenance

Most Fabtex window treatment systems are manufactured to provide maintenance-free performance for the life of the product. All internal and external components are designed to function without user intervention aside from normal operational input. After a product has been installed correctly by a qualified installer, there is no mechanical upkeep required with the exception of battery-powered motors , which will require charging after approximately every 400 cycles.

In the event adjustments or repairs are needed, the original provider of the systems should be notified. All adjustments and repairs must be made by qualified personnel.

Fabric-wrapped fascia or cornice

These only need light maintenance to stay dust and dirt free. Fascia fabric can be periodically dusted using a feather duster or vacuum with a soft brush attachment.

Managing Fabric Edge Fray

Fabrics containing PVC coated fiberglass yarns present an inherent characteristic that may result in edge fray. While Fabtex makes every effort to provide shades that do not exhibit this characteristic prior to shipment, some fraying may naturally occur during the life of the product. Should this happen, the following sections detail the reason for this occurrence and the steps to manage it.

Cause of Potential Edge Fray

Fabrics with PVC coated fiberglass yarns may exhibit small tufts of white fibers on the cut edges of the shades. When the fabrics are cut, the PVC coating is melted together on the edges. However, some strands of the fiberglass may not be sealed in PVC coating during the cutting process. These strands can fray over time and become visible. This is an inherent characteristic of the fabric.

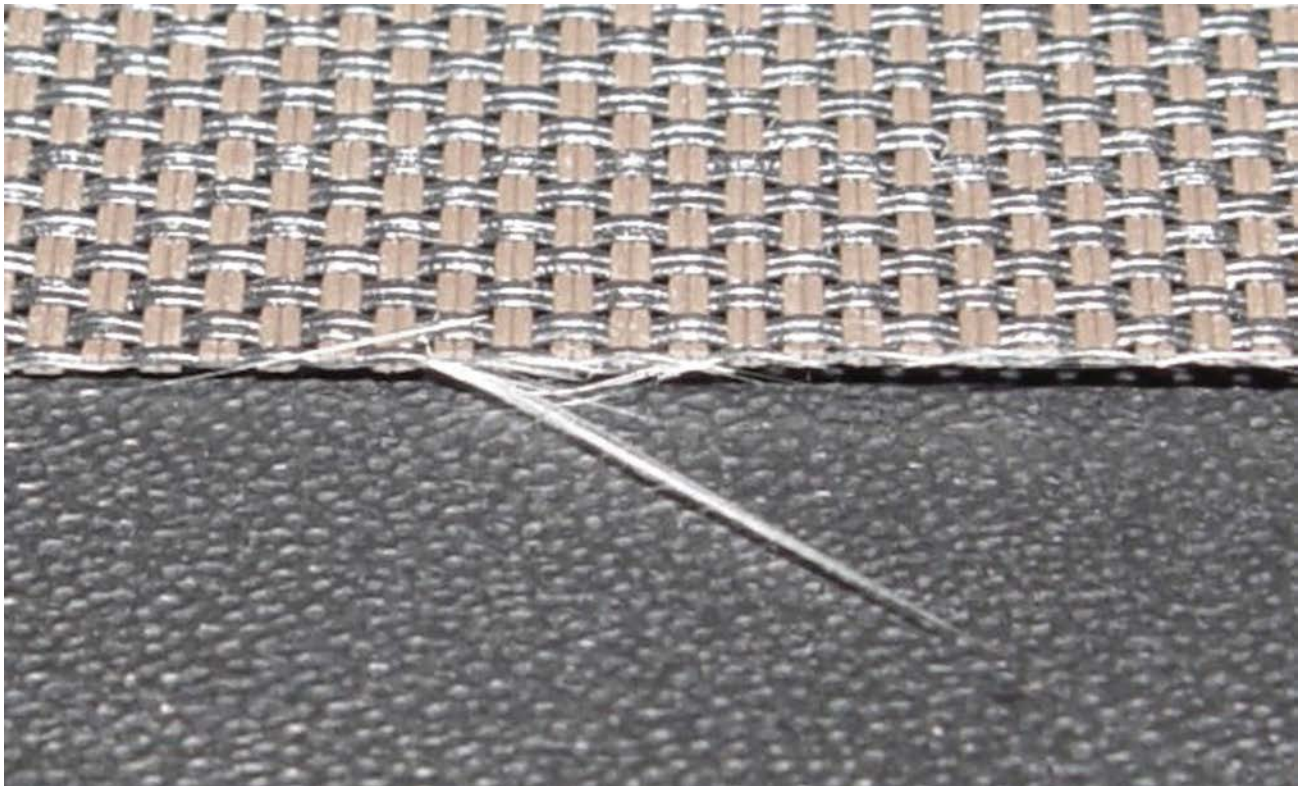

Trimming Frayed Fibers

Visible frays are trimmed at the factory, however residual frays may appear during shipping, installation, or operation of the shade. The best way to remove any developing frays is to trim them with a pair of sharp scissors.

Before trimming the fray, fluff the edge of the fabric with your hand to ensure that all frays are visible and can be trimmed more easily.

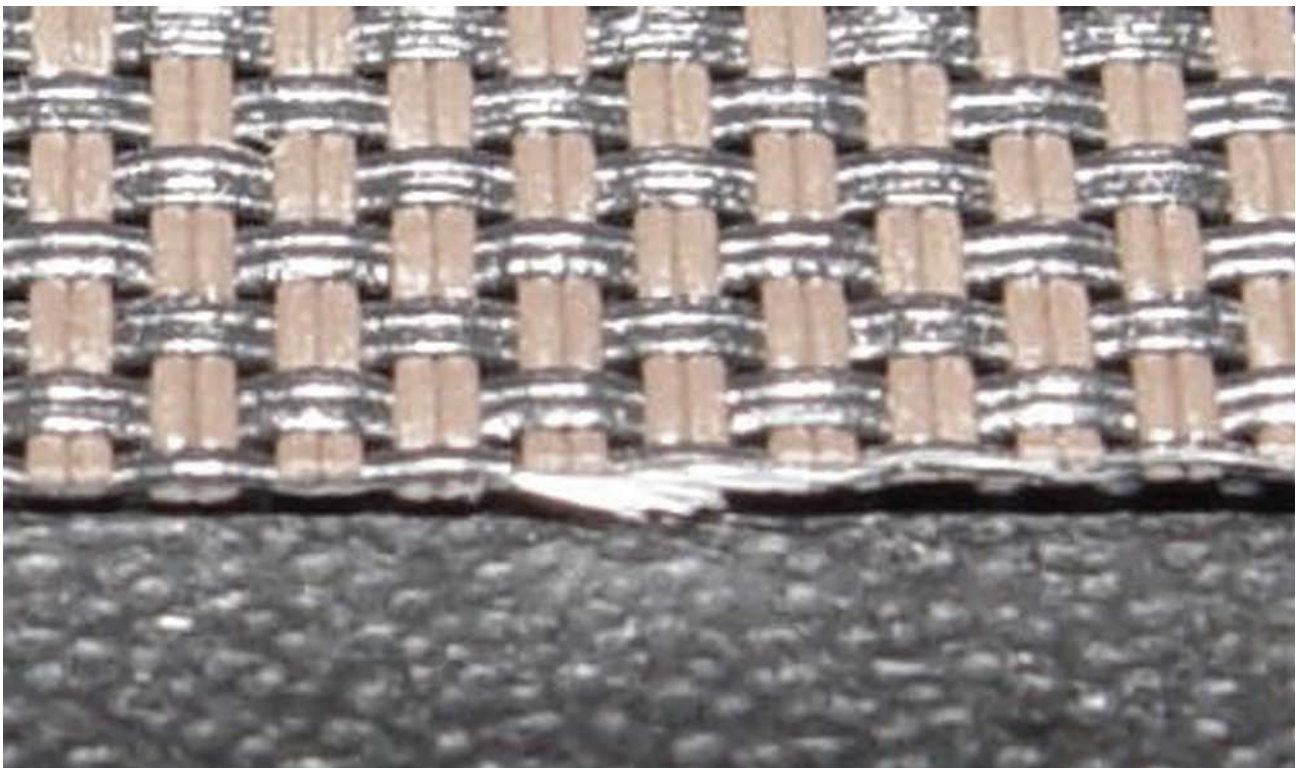

Detailing the Cut Edges

Fiberglass yarns are white and may still be visible after trimming, especially on dark fabrics. A permanent marker, such as an art marker, can be used to color the white fiber ends to help them blend in with the fabric. Art markers will dry quickly and won't smear. Black, gray, or brown colored markers will blend with most dark colored fabrics.

In a two-colored fabric the marker color should match the lighter fabric color.

Care should always be taken to ensure that the marker does not bleed onto the fabric and stain the edges. An inconspicuous spot should be tested first where it won't be seen if the colors don't match, such as the first fabric wrap on the shade tube.

Preventing Fabric From Rubbing on Other Objects

Frays may also be caused by the edge of the fabric rubbing on another object. Make sure that the path is clear before moving a shade.

Shade telescoping can also increase the appearance of fabric frays, especially if the fabric edge rubs on the brackets.



A F E T E R I K C O M P A N Y

Roller Shade Service Manual © 2022. Fabtex Inc.